

ICS4C Trivia Buzzer Project

As discussed, your mission is to make the two parts of our trivia buzzer system.

The Client

This is the simple button that participants in the trivia will smack to attempt to be the first to answer quiz questions. It is comprised very little. There is a 60mm button, an LED, and a phone jack (RJ11). There will be a very small PCB inside here to solder the wires to and house the RJ11 jack. The idea is the organizer would plug in a cable to each client and then plug the other end of the client into the host machine.

Here are the required parts for each client:

- 60mm button
- Green 5mm LED
- RJ11 Jack

Client Considerations:

The client should:

- Be simply focused on the button. Ideally the 3D printed container for the button should be minimal and only big enough to stabilize the button and provide a place to mount the circuit board and jack.

The Host

This is the more complicated part of the system. It will be the “brain” of the system, hold the arduino nano, connect all the devices, have a buzzer, power the system, etc.

Here are the required parts for each host:

- Arduino Nano
- 6x Green 5mm LED
- 7x RJ11 Jack
- 8x 0.1uF Capacitor
- 7x Diode
- 7x 50ohm Resistor
- 4x Mounting Hole
- 1x Big Button for clearing/resetting the game
- 1x Piezo buzzer
- 1x USB Type B Jack for power
- 1x 9V Battery holder for power
- 1x On/Off Switch to control power

Host Considerations:

- There should be 6 “client-side” jacks on one side, each with their own associated green LED visible on top.
- The other side (the ‘rear’) should expose the 7th jack and the USB Type B port. This will serve as connections for power, or to connect to another host further up the chain.
- The 9V Battery holder should fit nicely on the rest of this ‘rear’ long side.
- There should be a cutout to expose the USB connection of the Arduino Nano on one of the short sides.
- The PCB should be as small as is reasonable, as every increase in rectangular area costs more to manufacture. (*See the appendix for possible example PCB design*)
- Given you need to expose the LEDs on top, I would recommend designing your board upside down so that the LEDs will be attached on the bottom of the board, and the board itself mounted to the top inside of the box. This way the LEDs will be attached to the board and all the other parts will not interfere with mounting the board to the box.
- 4 Mounting holes will be added to screw the board into the plastic of the box.
- SEE REQUIRED WIRING BELOW

Parts List

Description	Component	Footprint
RJ11 Jacks	RJ connector, 6P4C	TO BE CONFIRMED
Arduino	Arduino_Nano_v3.x	Module:Arduino_Nano
Piezo Buzzer	Buzzer	TO BE CONFIRMED
Clear Button	SW_Push	Connector_PinHeader_2.54mm: PinHeader_1x02_P2.54mm_Vertical
Resistor	R	Resistor_THT: R_Axial_DIN0207_L6.3mm_D2.5mm_P7.62mm_Horizontal
Capacitor	C	TO BE CONFIRMED
Diode	D	TO BE CONFIRMED
On/Off Switch	SW_SPDT	TO BE CONFIRMED
USB Type B (Power)	USB_B	TO BE CONFIRMED
9V Battery	Battery	TO BE CONFIRMED
Mounting Hole	Mounting Hole	MountingHole:MountingHole_3.2mm_M3

Required Wiring

Each Jack should be wired like this:

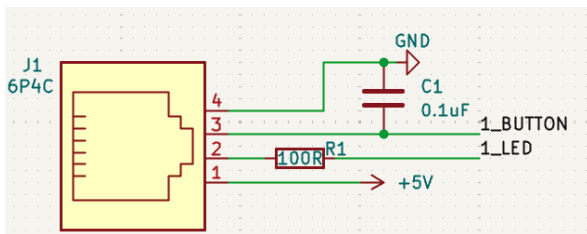

Diodes should be wired like this:

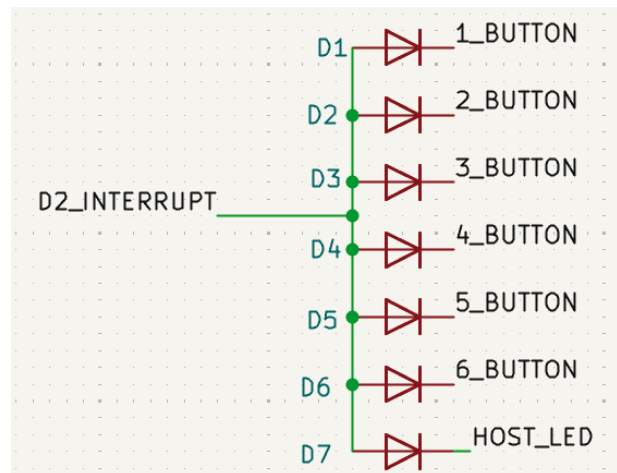

Power Switch

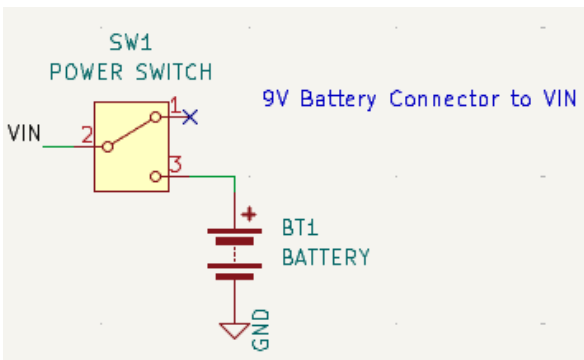

USB Type B

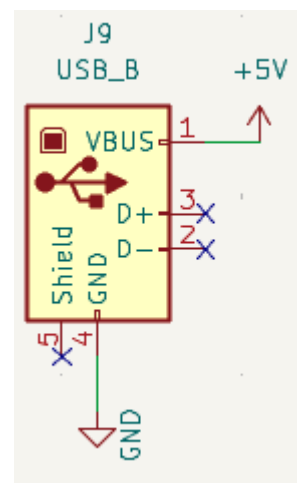

Arduino Wiring

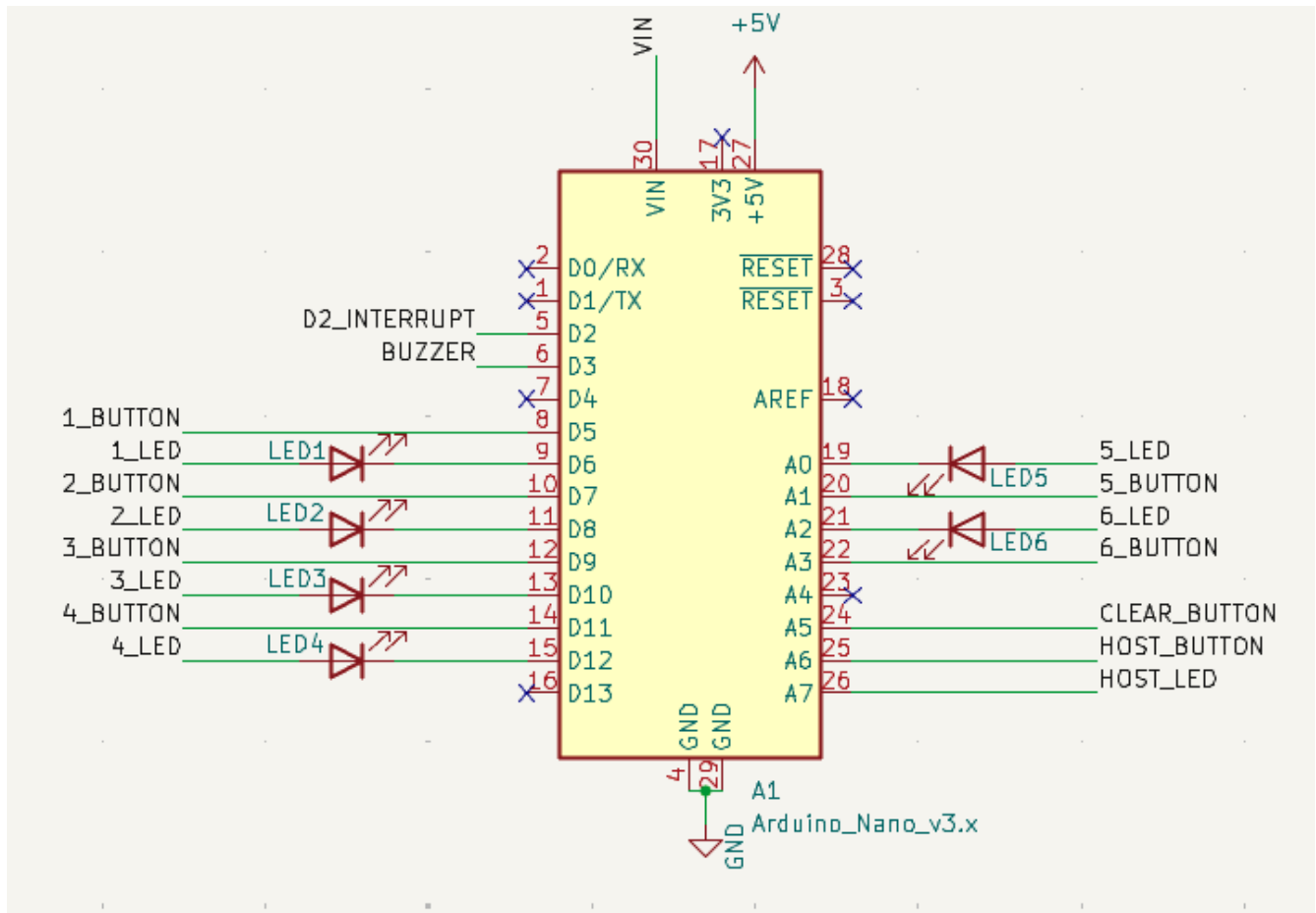

Buzzer & Clear Button

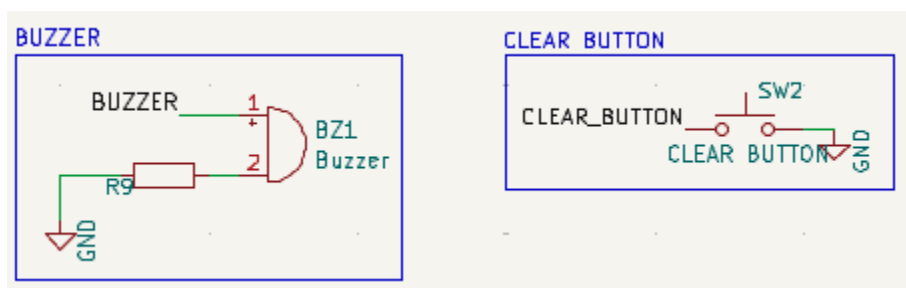

Host Jack

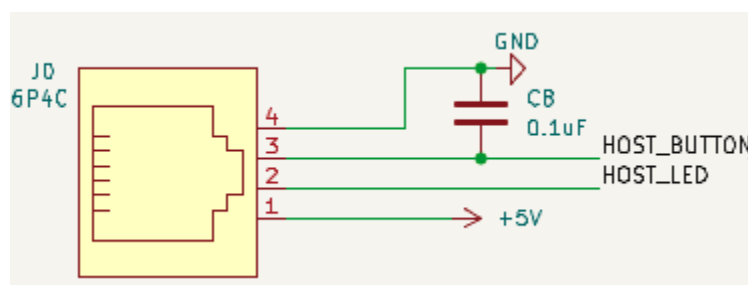

Possible Host PCB Layout

Front of board (mounted facing down)

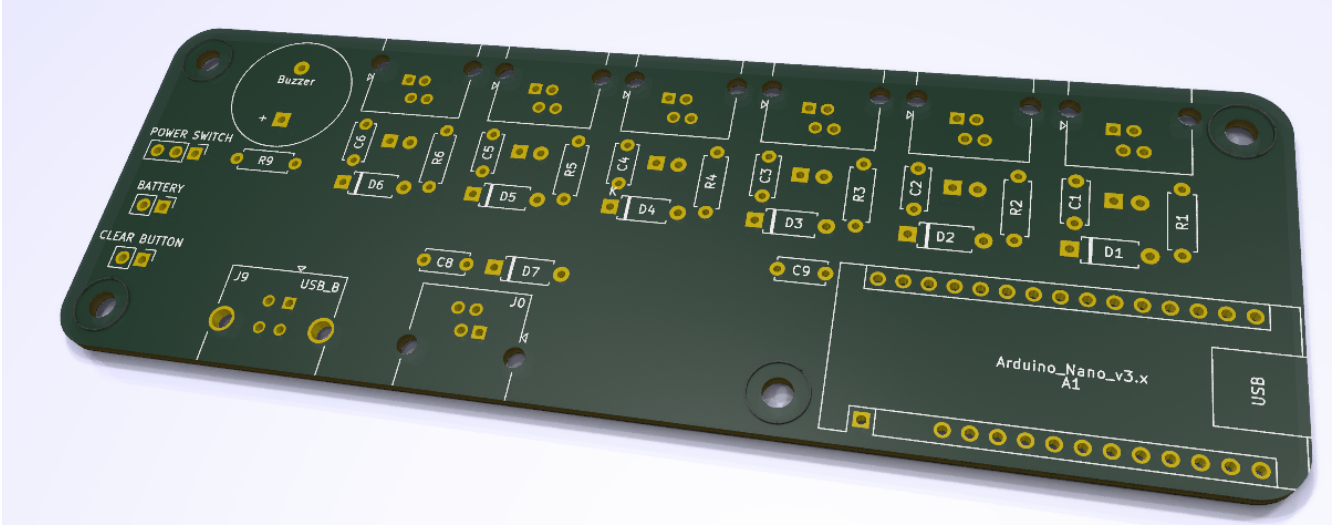

Back of board (mounted facing into the box)

